



## SNF 200

### Area floodlights

Self-contained floodlight luminaires complete with pre-wired control gear for 150W or 250W high-pressure sodium (SON/T) lamps. The luminaires feature high-efficiency asymmetric optics and versatile mounting arrangements.

#### RANGE

SNF 200/01 – Floodlight for 150W SON/T lamp.

SNF 200/02 – Floodlight for 250W SON/T lamp.

#### APPLICATIONS

Suitable for all floodlighting applications for which a well-controlled beam is appropriate, including:

- Areas and building sites
- Marshalling yards
- Building facades
- Car parks
- Industrial premises
- Floodlighting of buildings
- Statues and fountains

#### FEATURES

■ Sturdy housing in high-pressure die-cast aluminium with anti-corrosive black finish.

■ Light-controlling front cover is made of vandal-resistant polycarbonate which also resists yellowing from UV radiation.

■ Accurate asymmetric light control by means of high-grade aluminium reflectors and refracting cover ensures high efficiency.

■ Silicone rubber gasket seals front cover to housing with the Degree of Protection IP 55 (jetproof and dustproof).

■ All external parts are corrosion proof (stainless steel cover fixing screws; hot-dipped galvanised and painted steel mounting bracket).

■ Reversible cover permits pole, wall or ceiling mounting.

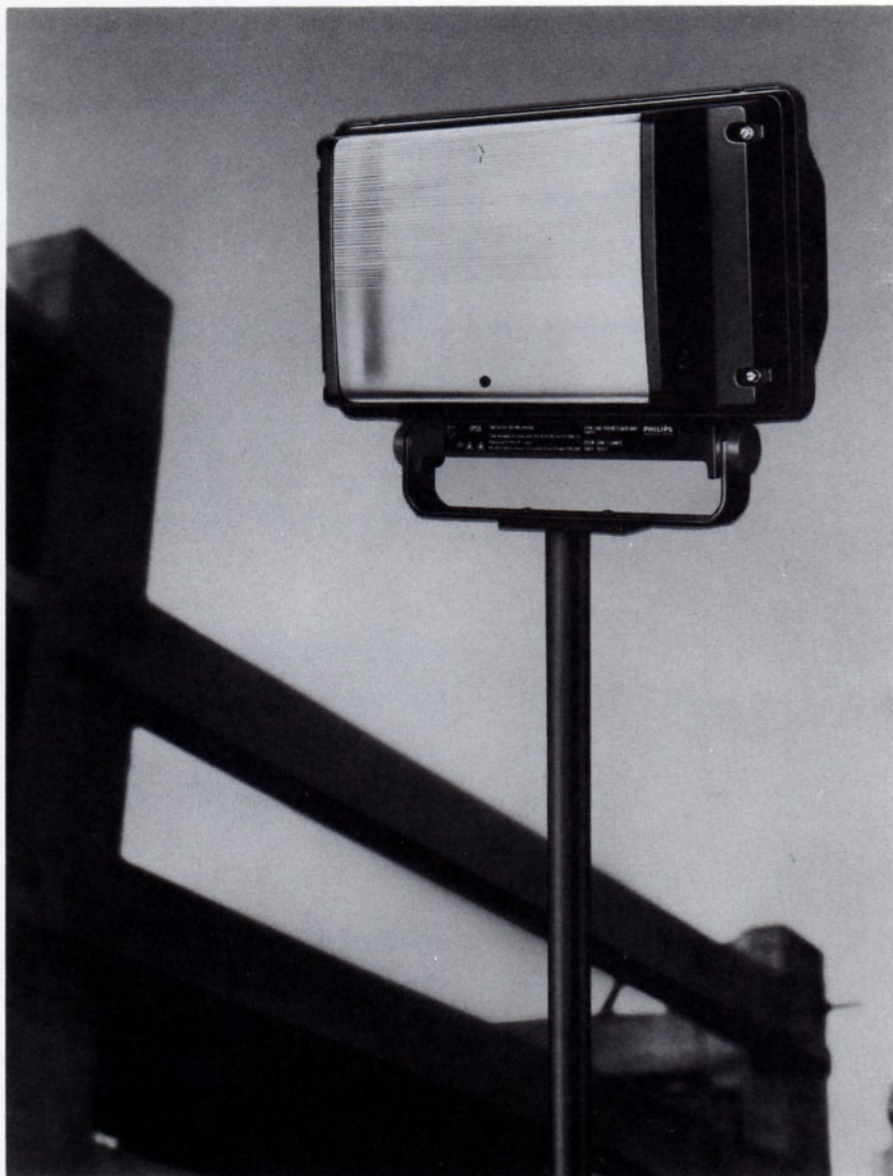

■ Integral control gear, prewired to three-way terminal block, permits simple connection to standard mains supplies.

■ Cable entry through sealing gland with built-in cable stress release.

■ Luminaire rotates through 200° on mounting bracket to give light throw in any direction.

■ Simple lamp changing by removing front cover does not disturb light throw adjustment.

■ Floodlight supplied with 1 x PG 13-5 cable gland.

■ Supplied complete with lamp.



## MATERIALS & FINISH

**Body:** High-pressure die-cast aluminium, black finish.

**Front cover:** High-pressure die-cast aluminium, black finish, with UV-resistant etched polycarbonate controller.

**Mounting bracket:** Mild steel, hot-dip galvanised and painted black.

## SPECIFICATION

■ Designed to comply with BS 4533 102.5 Class I electrical (earth required).

■ Degree of Protection IP 55.

## RANGE OF OPERATION

240V 50Hz supplies.

Indoor or normal outdoor applications.

## MOUNTING ADJUSTMENT

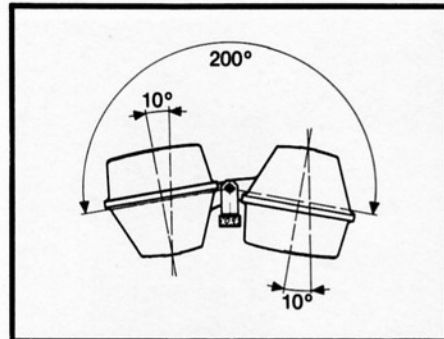

## DIMENSIONS

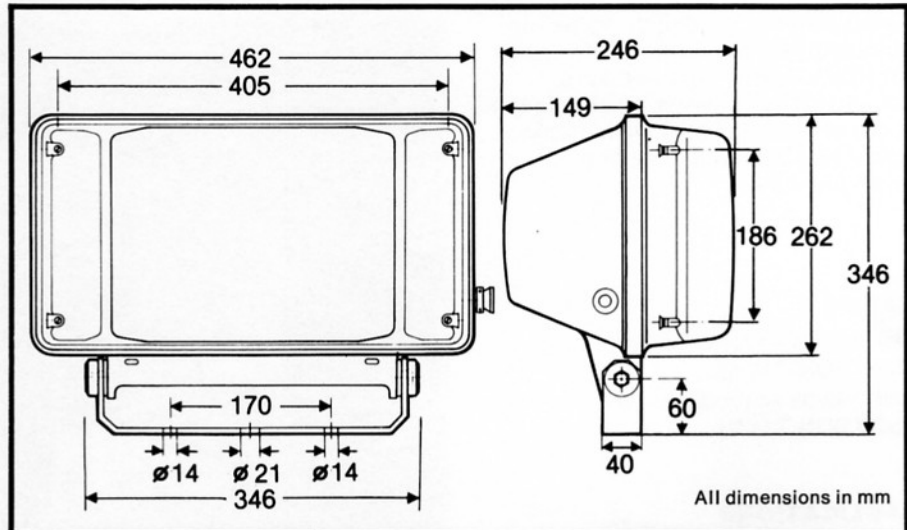

## WEIGHTS & ELECTRICAL DATA

Catalogue No.	Lamp type	Weight complete with lamp (kg)	Circuit current (A)	Total circuit Watts	Lamp cap
SNF 200/01	150W SON/T	7.5	0.90	174	GES
SNF 200/02	250W SON/T	8.4	1.30	280	GES

## ORDERING DATA

Catalogue No.	Description	Packing quantity
SNF 200/01	Luminaire with control gear and 150W SON/T lamp	Individually packed
SNF 200/02	Luminaire with control gear and 250W SON/T lamp	Individually packed

**Luminaire:** Made in Great Britain

For additional technical information, apply to Marwood Electrical Company Limited