



XGC 001

Mini SOX KombiPak

A high-quality luminaire, supplied as a KombiPak complete with 18W SOX lamp and all fixing accessories, for use as a ceiling or wall-mounted luminaire for security or amenity lighting.

APPLICATIONS

Suitable for use in domestic, public, commercial and industrial premises, in situations such as:-

- Parking areas
- Factory gates
- Banks
- Perimeter areas
- Loading bays
- Building sites
- Footpaths
- Schools
- Supermarkets
- Farmyards
- Museums

FEATURES

- Gives 40% more light than a typical 100W GLS bulkhead; but only dissipates 25W.
- Vandal-resistant prismatic controller enhances light distribution, enabling the luminaire to be used as an effective mini-lantern.
- When used as a bulkhead luminaire, a detachable side reflector directs light downwards, further improving efficiency.
- Modern, smart appearance.
- Suitable for indoor or outdoor use.
- High-efficiency low-pressure sodium lamp with low-loss integral control gear permits all-night burning, all the year round, for as little as 10p a week.
- Supplied as KombiPak, complete with all fixing accessories including lantern bracket.
- Familiar yellow sodium light gives excellent visual acuity and fog penetration.



MATERIALS & FINISH

Body: Black polyamide.

Prismatic controller: Polycarbonate, UV stabilised, vandal-resistant.

Gear tray: Steel, stove-enamelled white, with anodised aluminium reflector.

Sealing gasket: Silicone rubber, labyrinth type.

SPECIFICATION

■ Type compliance with BS 4533 Section 102.2

■ Degree of Protection IP54.

RANGE OF OPERATION

240V 50Hz.

WEIGHT

Luminaire 1.8 kg (complete with packing, bracket, accessories, etc.)

Bracket 0.2 kg.

Note: When mounted vertically, the prismatic controller must be at the bottom so that the lamp cap is uppermost. Cable entry is provided on the right-hand side, or from the top or the bottom.

Lamp: Made in Belgium.

Luminaire : Made in Holland.

DIMENSIONS

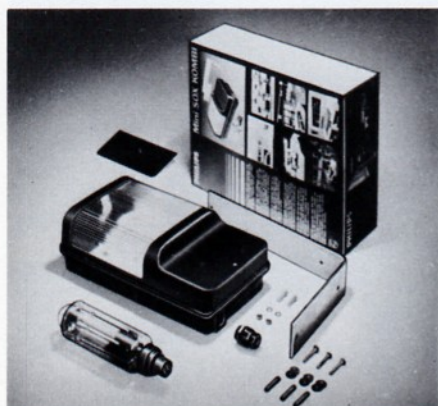
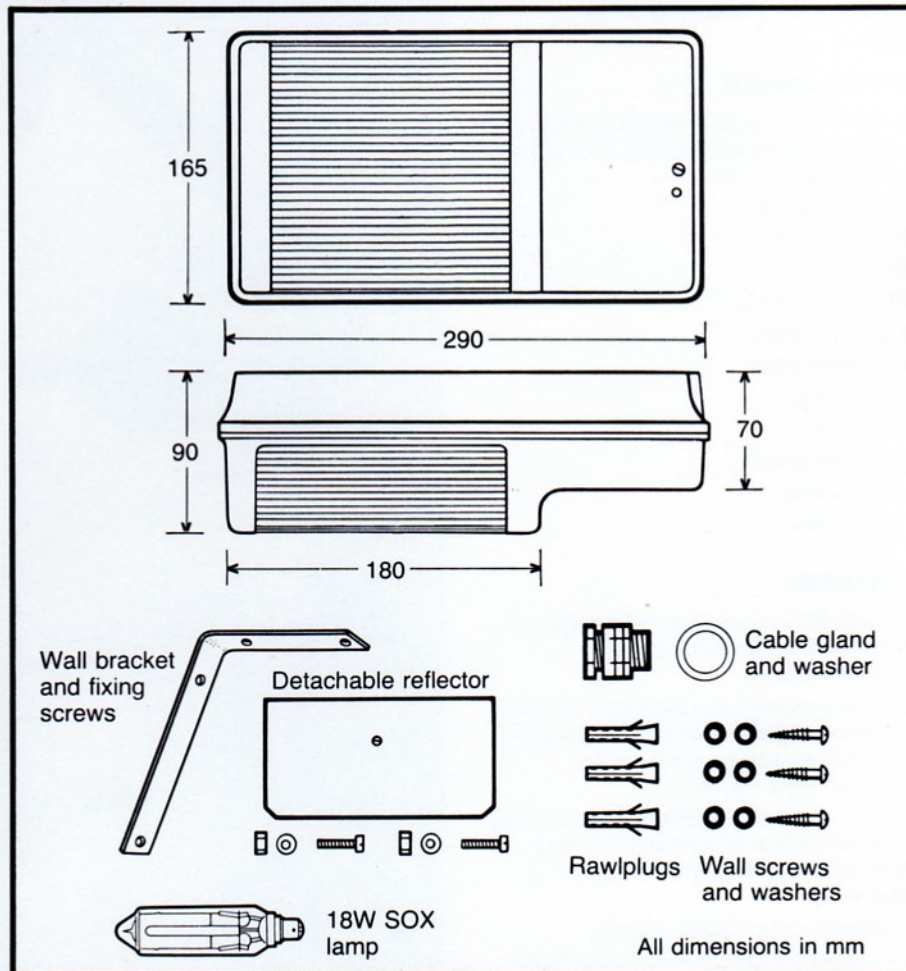

ELECTRICAL DATA

Lamp	Ballast	Capacitor	Ignitor	Mains voltage	Mains current (amps)	Circuit Watts
18W SOX	BSX 18	L 4005	—	240	0.14	25

ORDERING DATA

Catalogue No.	Description	Packing quantity
XGC 001	Luminaire with prismatic controller complete with 18W SOX lamp and all accessories	Individually packed

For additional technical information, apply to Marwood Electrical Company Limited